



EMERSONTM
Industrial Automation



User Guide

SI-I/O

Part Number: 0478-0047-03

Issue: 3



www.controltechniques.com

General Information

The manufacturer accepts no liability for any consequences resulting from inappropriate, negligent or incorrect installation or adjustment of the optional operating parameters of the equipment or from mismatching the variable speed drive with the motor.

The contents of this guide are believed to be correct at the time of printing. In the interests of a commitment to a policy of continuous development and improvement, the manufacturer reserves the right to change the specification of the product or its performance, or the contents of this guide, without notice.

All rights reserved. No parts of this guide may be reproduced or transmitted in any form or by any means, electrical or mechanical including photocopying, recording or by an information storage or retrieval system, without permission in writing from the publisher.

Drive software version

The SI-I/O can only be used with drive software version 01.02.00.xx onwards.

Contents

1	How to use this guide	4	10	Technical Data	36
1.1	Intended personnel	4	10.1	Digital inputs/outputs (Terminals 2-5)	36
1.2	Information	4	10.2	Digital Inputs (Terminals 7-9)	36
2	Safety information	5	10.3	Differential Analog Input (Terminals 7 and 8)	36
2.1	Warnings, Cautions and Notes	5	10.4	Single-ended Analog Inputs (Terminals 7-9) in Voltage input mode	37
2.2	Electrical safety - general warning	5	10.5	Single-ended Analog Input (Terminal 9) in Current input mode	37
2.3	System design and safety of personnel	5	10.6	Analog Output (Terminal 11) in Voltage output mode	37
2.4	Environmental limits	5	10.7	Analog Output (Terminal 11) in Current output mode	38
2.5	Access	5	10.8	Relays (Terminals 21-23)	38
2.6	Compliance with regulations	5			
2.7	Adjusting parameters	5			
2.8	Stored charge	6			
3	Introduction	7			
3.1	Features	7			
3.2	Option module identification	7			
3.3	Conventions used in this guide	7			
3.4	Digital I/O	8			
3.5	Analog I/O	8			
3.6	Relays	8			
3.7	24 V internal power supply	8			
4	Mechanical installation	9			
4.1	General installation	9			
5	Electrical installation	10			
5.1	Terminal descriptions	10			
5.2	Wiring, shield connections	10			
6	Single line descriptions	11			
6.1	Single line descriptions	11			
6.2	Menu 9 - Resources	14			
7	Parameters	15			
7.1	Menu 0 - Module Set-up	15			
7.2	Menu 1 - I/O Set-up	18			
7.3	Menu 2 - Digital I/O	23			
7.4	Menu 3 - Analog I/O	24			
7.5	Menu 9 - Resources	27			
8	Block diagrams	28			
8.1	Functional block diagrams	28			
9	Diagnostics	34			
9.1	Overview	34			

1 How to use this guide

1.1 Intended personnel

This guide is intended for personnel who have the necessary training and experience in system design, installation, commissioning and maintenance.

1.2 Information

This guide contains information covering the identification of the option module, terminal layout for installation, fitting of the option module to the drive, parameter details, diagnostic information and the specifications of the option module.

2 Safety information

2.1 Warnings, Cautions and Notes



A Warning contains information which is essential for avoiding a safety hazard.



A Caution contains information which is necessary for avoiding a risk of damage to the product or other equipment.

NOTE

A **Note** contains information which helps to ensure correct operation of the product.

2.2 Electrical safety - general warning

The voltages used in the drive can cause severe electrical shock and/or burns, and could be lethal. Extreme care is necessary at all times when working with or adjacent to the drive.

Specific warnings are given at the relevant places in this User Guide.

2.3 System design and safety of personnel

The drive is intended as a component for professional incorporation into complete equipment or a system. If installed incorrectly, the drive may present a safety hazard.

The drive uses high voltages and currents, carries a high level of stored electrical energy, and is used to control equipment which can cause injury.

Close attention is required to the electrical installation and the system design to avoid hazards either in normal operation or in the event of equipment malfunction. System design, installation, commissioning/start-up and maintenance must be carried out by personnel who have the necessary training and experience. They must read this safety information and this User Guide carefully.

The STOP and SAFE TORQUE OFF functions of the drive do not isolate dangerous voltages from the output of the drive or from any external option unit. The supply must be disconnected by an approved electrical isolation device before gaining to the electrical connections.

With the sole exception of the SAFE TORQUE OFF function, none of the drive functions must be used to ensure safety of personnel, i.e. they must not be used for safety-related functions.

Careful consideration must be given to the functions of the drive which might result in a hazard, either through their intended behavior or through incorrect operation due to a fault. In any application where a malfunction of the drive or its control system could lead to or allow damage, loss or injury, a risk analysis must be carried out, and where necessary, further measures taken to reduce the risk - for example, an over-speed protection device in case of failure of the speed control, or a fail-safe mechanical brake in case of loss of motor braking.

The system designer is responsible for ensuring that the complete system is safe and designed correctly according to the relevant safety standards.

2.4 Environmental limits

Instructions regarding transport, storage, installation and use of the drive must be complied with, including the specified environmental limits. These instructions can be found in the relevant drive documentation. Drives must not be subjected to excessive physical force.

2.5 Access

Drive access must be restricted to authorized personnel only. Safety regulations which apply at the place of use must be complied with.

2.6 Compliance with regulations

The installer is responsible for complying with all relevant regulations, such as national wiring regulations, accident prevention regulations and electromagnetic compatibility (EMC) regulations. Particular attention must be given to the cross-sectional areas of conductors, the selection of fuses or other protection, and protective ground (earth) connections.

Instructions for achieving compliance with specific EMC standards may be found in the relevant drive documentation.

Within the European Union, all machinery in which this product is used must comply with the following directives:

2006/42/EC: Safety of machinery.

2004/108/EC: Electromagnetic Compatibility.

2.7 Adjusting parameters

Some parameters have a profound effect on the operation of the drive. They must not be altered without careful consideration of the impact on the controlled system. Measures must be taken to prevent unwanted changes due to error or tampering.

2.8 Stored charge

The drive contains capacitors which remain charged to a potentially lethal voltage after the AC supply has been disconnected. If the drive has been energized, the AC supply must be isolated for at least ten minutes before work may continue.

3 Introduction

3.1 Features

All connections from the Option module to the drive are made via the drive connector. Connections from external equipment to the SI-I/O are made via a 3-way plugable/removable screw connector for the two relays, and an 11-way plugable/removable screw connector for the digital and analog I/O.

Figure 3-1 SI-I/O



All parameters associated with the SI-I/O can be found in section 7 *Parameters* on page 15.

3.2 Option module identification

SI-I/O can be identified by:

1. The label located on the top of the Option module.
2. The color coding across the front of the SI-I/O (Orange).

Figure 3-2 SI-I/O labels



1 Topside module label

2 Underside module label

3.2.1 Date code format

The date code is split into two sections: a letter followed by a number. The letter indicates the year, and the number indicates the week number (within the year) in which the Option module was built. The letters go in alphabetical order, starting with A in 1990 (B in 1991, C in 1992 etc).

Example:

A date code of V35 would correspond to week 35 of year 2012.

3.3 Conventions used in this guide

The configuration of the host drive and Option module is done using menus and parameters. A menu is a logical collection of parameters that have similar functionality. In the case of an Options module, the parameters will appear in menu 15, 16 or 17 depending on which slot the module is installed to. The menu is determined by the number before the decimal point.

The method used to determine the menu or parameter is as follows:

- Pr **S.mm.ppp** - Where S signifies the Option module slot number and mm.ppp signifies the menu and parameter number of the Option module's internal menus and parameters.
- Pr **MM.ppp** - Where MM signifies the menu allocated to the Option module set-up menu and ppp signifies the parameter number.

Pr **mm.000** - Signifies parameter number 000 in any drive menu.

All the inputs/outputs in the SI-I/O are user programmable for function and signal processing.

3.4 Digital I/O

NOTE By default, the digital inputs/outputs on the Option module are configured to operate in positive logic.

NOTE Configuration of the maximum of eight digital inputs for positive/negative logic is carried out by setting Pr **S.01.008**.

By default, the SI-I/O Module is set up for four programmable digital inputs/outputs. By configuring the analog I/O as digital inputs, it is possible for the SI-I/O module to have four programmable inputs/outputs and also four digital inputs.

The functionality of these terminals is as follows:

- The logic sense selected can be positive or negative
- The logic state of each input is monitored by a read-only parameter
- The logic state can be inverted
- The digital input can be programmed to any suitable destination bit parameter
- The digital output can be sourced from any suitable bit parameter
- The output can operate either as a push-pull or an open collector output

3.5 Analog I/O

By default, the SI-I/O is set up for three single-ended analog inputs and one analog output or one high resolution differential analog input, one single-ended analog input and one analog output.

Analog inputs 1 and 2 can only be configured as ± 10 Vdc voltage inputs or digital inputs. When both are configured as analog voltage inputs, they can be used as a single high resolution differential analog input.

Analog input 3 can operate in voltage mode (± 10 Vdc), current mode (0 to 20 mA) or as a digital input.

Analog output 1 can operate in voltage mode (± 10 Vdc), current mode (0 to 20 mA) or as a digital input.

NOTE

The high precision differential analog input and analog output is only supported on Unidrive M600 - M800.

3.6 Relays

The two relays can be used to convey the logic state of any suitable parameter to external equipment. The logic state is processed as follows:

- A suitable source parameter is assigned to each relay
- The logic state can be inverted
- The state of the relay is monitored by a parameter

3.7 24 V internal power supply

If the user load exceeds 400 mA at 24 V, (24 V internal power supply), then an external 24 V power supply will be required which should be connected to the drive's control terminals 1 and 2.

The user load comprises of:

- The drive's digital outputs plus the SI-I/O digital outputs

Or

- The drive's main encoder supply

The maximum output current from the drive's digital output terminals 22, 24, 25 and 26 is 240 mA at 24 V, exceeding this will result in an 'Output overload' digital output overload trip.

The SI-I/O has a maximum output current of 250 mA at 24 V across all four digital outputs.

NOTE If the maximum current of the drive and Option modules is exceeded a 'PSU 24V' 24 V internal power supply overload trip will result.

4 Mechanical installation

4.1 General installation

The installation of an Option module is illustrated in Figure 4-1.

Figure 4-1 Installing an Option module

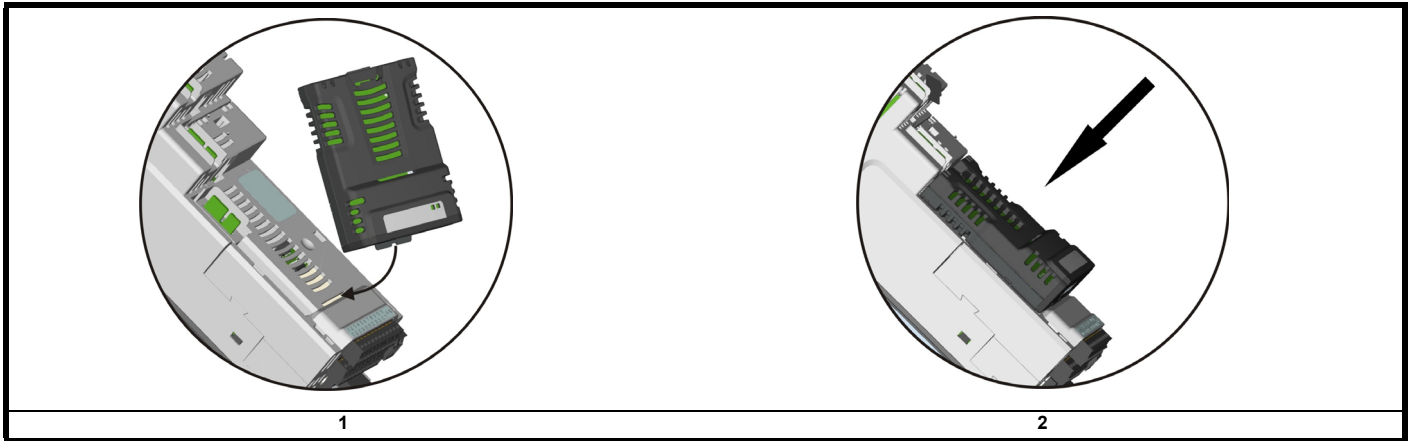

4.1.1 Installing the first Option module

- Option module slots must be used in the following order: slot 3, slot 2 and slot 1. Orientate the Option module above the drive as shown in (1). Align and insert the Option module tab into the slot (2). Press down on the Option module until it clicks into place.

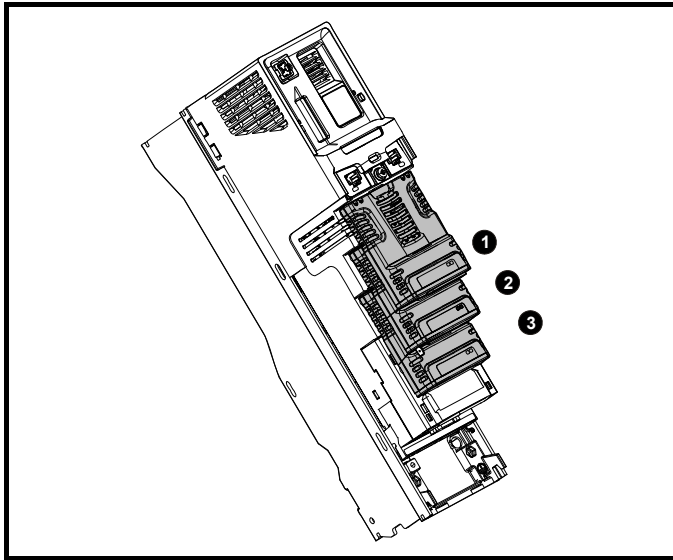

Adding Option modules: Populate slot 3 first, then slot 2 and finally slot 1

5 Electrical installation

5.1 Terminal descriptions

Table 5.1 SI-IO terminal descriptions

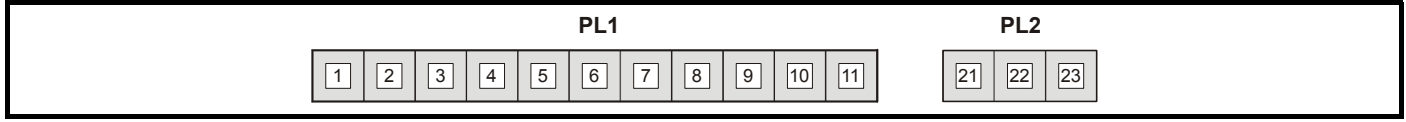

Table 5.2 11 way user connector and relay pin numbering

PL1	Function
T1	0 V common
T2	Digital input/output 1
T3	Digital input/output 2
T4	Digital input/output 3
T5	Digital input/output 4
T6	0 V common
T7	Analog input 1/digital input 5
T8	Analog input 2/digital input 6
T9	Analog input 3/digital input 7
T10	0 V common
T11	Analog output 1/digital input 8

PL2	Function
T21	Relay 1
T22	Relay common
T23	Relay 2

3 way 5.08 mm plugable screw connector

11 way 3.81 mm plugable screw connector

5.2 Wiring, shield connections

To prevent noise being induced onto any of the analog inputs or outputs, it is advisable to use twisted pair cable shielded with an overall outer shield. The shield connections should be terminated at one of the zero volt terminals on the Option module, and to the zero volt connection of the signal source. The termination of the shield should be kept as short as possible to prevent and noise being induced in this area.

Figure 5-1 Shield connections

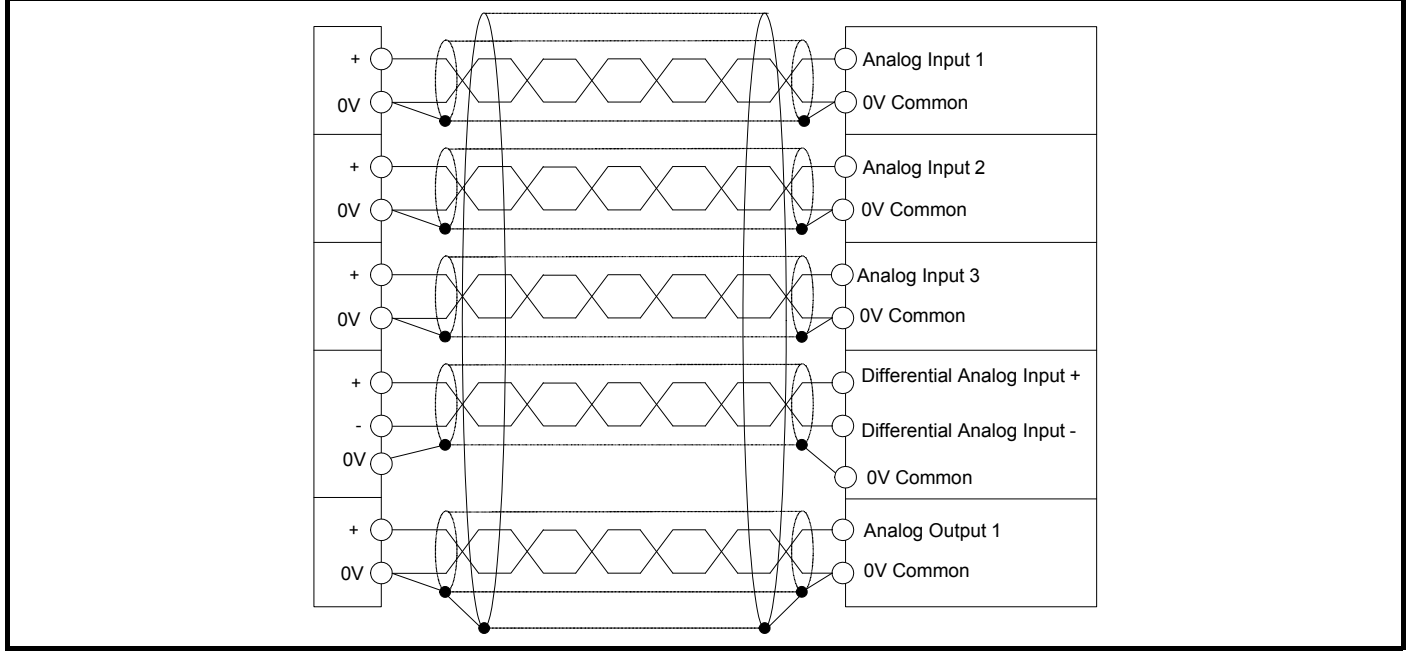

6 Single line descriptions

6.1 Single line descriptions

6.1.1 Menu 0 - Setup

Parameter		Range (⇄)	Default (⇒)	Type					
MM.001	Module ID	0 to 999	209	RO	Num	ND	NC	PT	
MM.002	Software Version	00.00.00.00 to 99.99.99.99		RO	Num	ND	NC	PT	
MM.003	Hardware Version	00.00 to 99.99		RO	Num	ND	NC	PT	
MM.004	Serial Number LS	0 to 999999999		RO	Num	ND	NC	PT	
MM.005	Serial Number MS	0 to 999999999		RO	Num	ND	NC	PT	
MM.006	Module status	Initializing (0), OK (1), Config (2), Error (3)		RO	Num	ND	NC	PT	
MM.007	Module reset	Off (0) or On (1)	Off (0)	RW	Bit		NC		
MM.008	Module default	Off (0) or On (1)	Off (0)	RW	Bit		NC		
MM.030	Slot Indicator	0 to 8		RO	Num	ND	NC	PT	
MM.031	Slot Menu Number	0 to 255		RO	Num	ND	NC	PT	

6.1.2 Menu 1 - I/O Setup

Parameter		Range (⇄)	Default (⇒)	Type					
S.01.001	Reset I/O Interface	Off (0) or On (1)	Off (0)	RW	Bit		NC		
S.01.002	Default I/O Interface	Off (0) or On (1)	Off (0)	RW	Bit		NC		
S.01.004	Option Module Status	Initializing (0), OK (1), Config (2), Error (3)		RO	Txt	ND	NC	PT	
S.01.005	I/O Output Enable Register	0000000000 to 1111111111	0000000000	RW	Bin				US
S.01.006	I/O Input Register	00000000 to 11111111		RO	Bin				US
S.01.007	I/O Output Register	0000000000 to 1111111111	0000000000	RW	Bin				US
S.01.008	Digital I/O Logic Polarity	Negative Logic (0) or Positive Logic (1)	Positive Logic (1)	RW	Txt				US
S.01.009	Open Collector Output	Push-Pull (0) or Open Collector (1)	Push-Pull (0)	RW	Txt				US
S.01.010	I/O Read Word	0000000000 to 1111111111	0000000000	RO	Bin				
S.01.011	T2 Digital I/O 1 Mode	Digital Input (0) or Digital Output (1)	Digital Input (0)	RW	Txt				US
S.01.012	T3 Digital I/O 2 Mode	Digital Input (0) or Digital Output (1)	Digital Input (0)	RW	Txt				US
S.01.013	T4 Digital I/O 3 Mode	Digital Input (0) or Digital Output (1)	Digital Input (0)	RW	Txt				US
S.01.014	T5 Digital I/O 4 Mode	Digital Input (0) or Digital Output (1)	Digital Input (0)	RW	Txt				US
S.01.015	T7 Digital Input 5 / Analog Input 1 Mode	Digital Input (0) or Volt IN (1)	Volt IN (1)	RW	Txt				US
S.01.016	T8 Digital Input 6 / Analog Input 2 Mode	Digital Input (0) or Volt IN (1)	Volt IN (1)	RW	Txt				US
S.01.017	T9 Digital Input 7 / Analog Input 3 Mode	Digital Input (0), Volt IN (1), 4-20mA Low (2), 20-4mA Low (3), 4-20mA Hold (4), 20-4mA Hold (5), 0-20mA (6), 20-0mA (7), 4-20mA Trip (8), 20-4mA Trip (9), 4-20mA (10), 4-20mA (11)	Volt IN (1)	RW	Txt				US
S.01.018	T11 Digital Input 8 / Analog Output 1 Mode	Digital Input (0), Volt Out (1), 4-20mA (2), 20-4mA (3), 0-20mA (4), 20-0mA (5),	Volt Out (1)	RW	Txt				US

6.1.3 Menu 2 - Digital I/O

Parameter		Range (⇄)	Default (⇌)	Type					
S.02.001	Digital I/O 1 State	Off (0) or On (1)		RO	Bit	ND	NC	PT	
S.02.002	Digital I/O 2 State	Off (0) or On (1)		RO	Bit	ND	NC	PT	
S.02.003	Digital I/O 3 State	Off (0) or On (1)		RO	Bit	ND	NC	PT	
S.02.004	Digital I/O 4 State	Off (0) or On (1)		RO	Bit	ND	NC	PT	
S.02.005	Digital Input 5 State	Off (0) or On (1)		RO	Bit	ND	NC	PT	
S.02.006	Digital Input 6 State	Off (0) or On (1)		RO	Bit	ND	NC	PT	
S.02.007	Digital Input 7 State	Off (0) or On (1)		RO	Bit	ND	NC	PT	
S.02.008	Digital Input 8 State	Off (0) or On (1)		RO	Bit	ND	NC	PT	
S.02.009	Relay 1 State	Off (0) or On (1)		RO	Bit	ND	NC	PT	
S.02.010	Relay 2 State	Off (0) or On (1)		RO	Bit	ND	NC	PT	
S.02.011	Digital I/O 1 Invert	Off (0) or On (1)	Off (0)	RW	Bit				US
S.02.012	Digital I/O 2 Invert	Off (0) or On (1)	Off (0)	RW	Bit				US
S.02.013	Digital I/O 3 Invert	Off (0) or On (1)	Off (0)	RW	Bit				US
S.02.014	Digital I/O 4 Invert	Off (0) or On (1)	Off (0)	RW	Bit				US
S.02.015	Digital Input 5 Invert	Off (0) or On (1)	Off (0)	RW	Bit				US
S.02.016	Digital Input 6 Invert	Off (0) or On (1)	Off (0)	RW	Bit				US
S.02.017	Digital Input 7 Invert	Off (0) or On (1)	Off (0)	RW	Bit				US
S.02.018	Digital Input 8 Invert	Off (0) or On (1)	Off (0)	RW	Bit				US
S.02.019	Relay 1 Invert	Off (0) or On (1)	Off (0)	RW	Bit				US
S.02.020	Relay 2 Invert	Off (0) or On (1)	Off (0)	RW	Bit				US
S.02.021	Digital I/O 1 Source / Destination	0.00.000 to 4.99.999	0.00.000	RW	Num			PT	US
S.02.022	Digital I/O 2 Source / Destination	0.00.000 to 4.99.999	0.00.000	RW	Num			PT	US
S.02.023	Digital I/O 3 Source / Destination	0.00.000 to 4.99.999	0.00.000	RW	Num			PT	US
S.02.024	Digital I/O 4 Source / Destination	0.00.000 to 4.99.999	0.00.000	RW	Num			PT	US
S.02.025	Digital Input 5 Destination	0.00.000 to 4.99.999	0.00.000	RW	Num			PT	US
S.02.026	Digital Input 6 Destination	0.00.000 to 4.99.999	0.00.000	RW	Num			PT	US
S.02.027	Digital Input 7 Destination	0.00.000 to 4.99.999	0.00.000	RW	Num			PT	US
S.02.028	Digital Input 8 Destination	0.00.000 to 4.99.999	0.00.000	RW	Num			PT	US
S.02.029	Relay 1 Source	0.00.000 to 4.99.999	0.00.000	RW	Num			PT	US
S.02.030	Relay 2 Source	0.00.000 to 4.99.999	0.00.000	RW	Num			PT	US

6.1.4 Menu 3 - Analog I/O

Parameter		Range (⌘)	Default (⇄)	Type					
S.03.001	Analog Input 1	-100.00 to 100.00%		RO	Num	ND	NC	PT	
S.03.002	Analog Input 2	-100.00 to 100.00%		RO	Num	ND	NC	PT	
S.03.003	Analog Input 3	-100.00 to 100.00%		RO	Num	ND	NC	PT	
S.03.004	Differential Analog Input	-100.0000 to 100.0000%		RO	Num	ND	NC	PT	
S.03.005	Analog Output 1	-100.00 to 100.00%		RO	Num	ND	NC	PT	
S.03.006	Analog Output 1 Source	0.00.000 to 4.99.999	0.00.000	RW	Num				US
S.03.007	Analog Output 1 Scaling	0.000 to 40.000	1.000	RW	Num				US
S.03.011	Analog Input 1 Offset	-100.00 to 100.00%	0.00%	RW	Num				US
S.03.012	Analog Input 1 Scaling	0.000 to 40.000	1.000	RW	Num				US
S.03.013	Analog Input 1 Invert	Off (0) or On (1)	Off (0)	RW	Bit				US
S.03.014	Analog Input 1 Minimum	-100.00 to 100.00%	-100.00%	RW	Num				US
S.03.015	Analog Input 1 Maximum	-100.00 to 100.00%	100.00%	RW	Num				US
S.03.016	Analog Input 1 Destination	0.00.000 to 4.99.999	0.00.000	RW	Num	DE			US
S.03.021	Analog Input 2 Offset	-100.00 to 100.00%	0.00%	RW	Num				US
S.03.022	Analog Input 2 Scaling	0.000 to 40.000	1.000	RW	Num				US
S.03.023	Analog Input 2 Invert	Off (0) or On (1)	Off (0)	RW	Bit				US
S.03.024	Analog Input 2 Minimum	-100.00 to 100.00%	-100.00%	RW	Num				US
S.03.025	Analog Input 2 Maximum	-100.00 to 100.00%	100.00%	RW	Num				US
S.03.026	Analog Input 2 Destination	0.00.000 to 4.99.999	0.00.000	RW	Num	DE			US
S.03.031	Analog Input 3 Offset	-100.00 to 100.00%	0.00%	RW	Num				US
S.03.032	Analog Input 3 Scaling	0.000 to 40.000	1.000	RW	Num				US
S.03.033	Analog Input 3 Invert	Off (0) or On (1)	Off (0)	RW	Bit				US
S.03.034	Analog Input 3 Minimum	-100.00 to 100.00%	-100.00%	RW	Num				US
S.03.035	Analog Input 3 Maximum	-100.00 to 100.00%	100.00%	RW	Num				US
S.03.036	Analog Input 3 Destination	0.00.000 to 4.99.999	0.00.000	RW	Num	DE			US
S.03.037	Analog Input 3 Current Loop Loss	Off (0) or On (1)		RO	Num	ND	NC	PT	
S.03.041	Differential Analog Input Offset	-100.00 to 100.00%	0.00%	RW	Num				US
S.03.042	Differential Analog Input Scaling	0.000 to 40.000	1.000	RW	Num				US
S.03.043	Differential Analog Input Invert	Off (0) or On (1)	Off (0)	RW	Bit				US
S.03.044	Differential Analog Input Minimum	-100.00 to 100.00%	-100.00%	RW	Num				US
S.03.045	Differential Analog Input Maximum	-100.00 to 100.00%	100.00%	RW	Num				US
S.03.046	Differential Analog Input Destination	0.00.000 to 4.99.999	0.00.000	RW	Num	DE			US

6.2 Menu 9 - Resources

Parameter		Range (⇅)	Default (⇒)	Type					
S.09.030	PCB temperature	-128 to 127°C		RO	Num	ND	NC	PT	
S.09.031	CPU Core Temperature	-128 to 127°C		RO	Num	ND	NC	PT	

7 Parameters

7.1 Menu 0 - Module Set-up

All parameters in **S.00.ppp** (i.e. menu 0 within the option module menus) are also present in menus 15, 16 or 17 depending on the slot that the module is installed to e.g. Pr **3.00.007** is also present as **17.007**.

The functionality and properties of the parameters are identical between the two menus.

S.00.001	Module ID		
Minimum	0	Maximum	65535
Default	209	Units	
Type	16 Bit Volatile	Update Rate	Power-up write
Display Format	None	Decimal Places	0
Coding	RO, ND, NC, PT, BU		

Pr **S.00.001** displays the ID number for the Option Module. For SI-I/O, this is 209.

S.00.002	Firmware version		
Minimum	0 (Display 00.00.00.00)	Maximum	99999999 (Display 99.99.99.99)
Default		Units	
Type	32 Bit Volatile	Update Rate	Power-up write
Display Format	Version Number	Decimal Places	0
Coding	RO, ND, NC, PT		

The firmware version of the option module is in the format of **ww.xx.yy.zz**

S.00.003	Hardware version		
Minimum	00.00	Maximum	99.99
Default		Units	
Type	16 Bit Volatile	Update Rate	Power-up write
Display Format	None	Decimal Places	2
Coding	RO, ND, NC, PT		

The firmware version of the option module is in the format of **ww.xx.yy.zz**

S.00.004	Serial Number LS		
S.00.005	Serial Number MS		
Minimum	0	Maximum	99999999
Default		Units	
Type	32 Bit Volatile	Update Rate	Power-up write
Display Format	None	Decimal Places	0
Coding	RO, ND, NC, PT		

The module serial number is available as a pair of 32-bit values where Serial Number LS (Pr **S.00.004**) provide the least significant 8 decimal digits, and Serial Number MS (Pr **S.00.005**) provides the most significant 8 decimal digits. The reconstructed serial number is ((S.00.005 x 10000000) + S.00.004). For example serial number "0001234567898765" would be stored as S.00.005 = 123456 and S.00.004 = 67898765.

S.00.006		Module Status	
Minimum	0	Maximum	101
Default		Units	
Type	8 Bit Volatile	Update Rate	Background read
Display Format	None	Decimal Places	0
Coding	RO, TE, ND, NC, PT		

This parameter displays the current status of the module. All possible values are shown in the table below.

Value	Text	Description
0	Initializing	Module is currently initializing.
1	Ok	Module has initialized and has found no errors.
2	Config	A configuration error has been detected in one of the communications protocols or user program
3	Error	An error has occurred preventing the firmware or user program from running correctly.
100	Bootloader	The bootloader is currently running.
101	Updating	The bootloader is currently performing a firmware update. The power must not be turned off in this state.

S.00.007		Reset Module	
Minimum	0	Maximum	1
Default	0	Units	
Type	1 Bit Volatile	Update Rate	Read every 200 ms
Display Format	None	Decimal Places	0
Coding	RW, NC		

Changes to the module's configuration will not take effect until the module has been reset.

- To reset the module:
- Set Pr **S.00.007** to On (1).
- When the sequence has been completed, Pr **S.00.007** will be reset to Off (0).

The module will reset using the updated configuration.

NOTE

This sequence does NOT store the module's configuration parameters in the drive or the module's flash memory. This parameter will change back to Off immediately, and as such the change may not be visible in the display.

S.00.008		Default Module	
Minimum	0	Maximum	1
Default	0	Units	
Type	1 Bit Volatile	Update Rate	Read every 200 ms
Display Format	None	Decimal Places	0
Coding	RW, NC		

If the host drive is defaulted (see the drive user guide for details), it will also clear the current configuration for the slot the module is installed to.

This can be performed as follows:

- Set Pr **S.00.008** to On.
- Reset the module by setting Pr **S.00.007** to On.
- Default parameter values for the module will be loaded.

The module will reset using the default values.

S.00.030		Slot Indicator	
Minimum	0	Maximum	8
Default		Units	
Type	8 Bit Volatile	Update Rate	Written on power-up
Display Format	None	Decimal Places	0
Coding	RO, ND, NC, PT, BU		

This parameter shows the slot number that the module is installed in.

S.00.031		Slot Menu Number	
Minimum	0	Maximum	255
Default		Units	
Type	8 Bit Volatile	Update Rate	Written on power-up
Display Format	None	Decimal Places	0
Coding	RO, ND, NC, PT, BU		

This parameter shows the drive menu number associated with the slot that the module is installed in.

For example:

- If the module is installed in slot 1, this parameter will show 15.
- If the module is installed in slot 2, this parameter will show 16.
- If the module is installed in slot 3, this parameter will show 17.

7.2 Menu 1 - I/O Set-up

Menu 1 contains all the parameters relating to the setup of the I/O interface on the SI-I/O module.

S.01.001 Reset I/O Interface			
Minimum	0	Maximum	1
Default	0	Units	
Type	1 Bit Volatile	Update Rate	Read every 200 ms
Display Format	None	Decimal Places	0
Coding	RW, NC		

Changes to the module's configuration will not take effect until the module has been reset.

To reset the module:

- Set Pr **S.01.001** to On (1).
- When the sequence has been completed, Pr **S.01.001** will be reset to Off (0).
- The module will reset using the updated configuration.

NOTE

This sequence does NOT store the module's configuration parameters in the drive or the module's flash memory. This parameter will change back to Off immediately, and as such the change may not be visible in the display.

S.01.002 Default I/O Interface			
Minimum	0	Maximum	1
Default	0	Units	
Type	1 Bit Volatile	Update Rate	Read every 200 ms
Display Format	None	Decimal Places	0
Coding	RW, NC		

If the host drive is defaulted (see the drive user guide for details), it will also clear the current configuration for the slot the module is installed to.

This can be performed as follows:

- Set Pr **S.01.002** to On.
- Reset the module by setting Pr **S.01.001** to On.
- Default parameter values for the module will be loaded.

The module will reset using the default values.

S.01.004 Option Module Status			
Minimum	0	Maximum	2
Default		Units	
Type	8 Bit Volatile	Update Rate	Background read
Display Format	None	Decimal Places	0
Coding	RO, TE, ND, NC, PT		

This parameter displays the current status of the module. All possible values are shown in the table below.

Value	Text	Description
0	Running OK	The module is healthy.
1	Initializing	Indicates that the module is initializing.
2	Mapping Error	Indicates that there is an error in the mapping parameters. For example, the destination should not be non-existent or read-only.
3	Error	An error has occurred preventing the firmware or user program from running correctly.
100	Bootloader	The bootloader is currently running.
101	Updating	The bootloader is currently performing a firmware update. The power must not be turned off in this state.

S.01.005		I/O Output Enable Register	
Minimum	0 (Display 0000000000)	Maximum	1023 (Display 1111111111)
Default	0	Units	
Type	16 Bit User Save	Update Rate	Background read
Display Format	Binary	Decimal Places	0
Coding	RW		

Parameter **S.01.005** is used to disable or enable relevant bits in the Output Register (Pr **S.01.007**).

If the bit is set to zero, the relevant bit in the Output Register (Pr **S.01.007**) is disabled. If the bit is set to 1 then the relevant bit in the Output Register can be used to directly control the digital output but the conditions below will need to be fulfilled:

- The corresponding bit in the I/O Output Enable Register (Pr **S.01.005**) is set to 1.
- The I/O must be a digital I/O and configured as an output or is a Relay Output.
- The corresponding I/O Source/Destination parameter must be set to 00.000.

If the above conditions are not met, then the digital output is controlled by the normal logic.

The table below shows how the bits correspond to each function.

Bit	9	8	7	6	5	4	3	2	1	0
Terminal	T23	T21	T11	T9	T8	T7	T5	T4	T3	T2
Terminal description	Relay 2	Relay 1	Digital Input 8	Digital Input 7	Digital Input 6	Digital Input 5	Digital I/O 4	Digital I/O 3	Digital I/O 2	Digital I/O 1

S.01.006		I/O Input Register	
Minimum	0 (Display 000000000)	Maximum	255 (Display 111111111)
Default	0	Units	
Type	16 Bit Volatile	Update Rate	1 ms write
Display Format	Binary	Decimal Places	0
Coding	RO		

The Digital I/O Input Register (Pr **S.01.006**) is always active and displays the state of all the digital I/O which are configured as inputs.

This register is updated every 1 ms.

The table below shows how the bits correspond to each function.

Bit	7	6	5	4	3	2	1	0
Terminal	T11	T9	T8	T7	T5	T4	T3	T2
Terminal description	Digital Input 8	Digital Input 7	Digital Input 6	Digital Input 5	Digital I/O 4	Digital I/O 3	Digital I/O 2	Digital I/O 1

S.01.007		I/O Output Register	
Minimum	0 (Display 0000000000)	Maximum	1023 (Display 1111111111)
Default	0	Units	
Type	16 Bit User Save	Update Rate	2 ms read
Display Format	Binary	Decimal Places	0
Coding	RW		

Bits in the I/O Output Register (Pr **S.01.007**) can be used to control the digital I/O directly. The bits control the output directly and are not modified by the corresponding Digital I/O Invert function. The bits in the I/O Output Register (Pr **S.01.007**) only control the corresponding digital output if all the conditions below are met:

- The corresponding bit in the I/O Output Enable Register (Pr **S.01.005**) is set to 1.
- The I/O must be a digital I/O and configured as an output or is a Relay Output.
- The corresponding I/O Source/Destination parameter must be set to 00.000.

If the above conditions are not met, then the digital output is controlled by the normal logic.

The table below shows how the bits correspond to each function.

Bit	9	8	7	6	5	4	3	2	1	0
Terminal	T23	T21	T11	T9	T8	T7	T5	T4	T3	T2
Terminal description	Relay 2	Relay 1	Digital Input 8	Digital Input 7	Digital Input 6	Digital Input 5	Digital I/O 4	Digital I/O 3	Digital I/O 2	Digital I/O 1

S.01.008 Digital I/O Logic Polarity			
Minimum	0	Maximum	1
Default	1	Units	
Type	8 Bit User Save	Update Rate	Background read
Display Format	None	Decimal Places	0
Coding	RW, TE		

This parameter controls the logic for all the digital inputs on the module.

Value	Text	Description
0	Negative Logic	Negative Logic
1	Positive Logic	Positive Logic

S.01.009 Open Collector Output			
Minimum	0	Maximum	1
Default	0	Units	
Type	8 Bit User Save	Update Rate	Background read
Display Format	None	Decimal Places	0
Coding	RW, TE		

Value	Text	Description
0	Push-pull	Push-pull output
1	Open Collector	Open Collector output

S.01.010 I/O Read Word			
Minimum	0 (Display 00000000)	Maximum	255 (Display 11111111)
Default	0	Units	
Type	16 Bit Volatile	Update Rate	Background read
Display Format	None	Decimal Places	0
Coding	RO		

The I/O Read Word (Pr **S.01.010**) reflects the state of digital I/O 1 - 8. Each bit matches the value of the state parameter for the respective digital input or output so the bit value for the digital inputs will be the state of the actual input before any inversion selection is applied. The bit value for the digital output will include the state inversion if selected in the invert parameter for the output.

The table below shows how the bits correspond to each function.

Bit	7	6	5	4	3	2	1	0
Terminal	T11	T9	T8	T7	T5	T4	T3	T2
Terminal description	Digital Input 8	Digital Input 7	Digital Input 6	Digital Input 5	Digital I/O 4	Digital I/O 3	Digital I/O 2	Digital I/O 1

S.01.011 T2 Digital I/O 1 Mode			
S.01.012 T3 Digital I/O 2 Mode			
S.01.013 T4 Digital I/O 3 Mode			
S.01.014 T5 Digital I/O 4 Mode			
Minimum	0	Maximum	1
Default	0	Units	
Type	8 Bit User Save	Update Rate	Background read
Display Format	None	Decimal Places	0
Coding	RW, TE		

Digital I/O 1-4 are the standard I/O that are compatible with IEC61131-2 logic levels. When the channel mode is set to zero, the I/O is configured as a digital input. When the channel mode is set to one, the I/O is configured as a digital output.

Value	Text	Description
0	Digital Input	Digital Input
1	Digital Output	Digital Output

S.01.015	T7 Digital Input 5, Analog Input 1 Mode		
S.01.016	T8 Digital Input 6, Analog Input 2 Mode		
Minimum	0	Maximum	1
Default	1	Units	
Type	8 Bit User Save	Update Rate	Background read
Display Format	None	Decimal Places	0
Coding	RW, TE		

Terminals 7 and 8 can be configured as digital inputs, analog voltage inputs or a single differential analog input.

Value	Text	Description	Function of T7	Function of T8
0	Digital Input	Digital Input	Digital Input 5	Digital Input 6
1	Volt IN	Analog Voltage Input	Analog Input 1	Analog Input 2
2	Differential	Differential Analog Voltage Input	Positive Differential Analog Input	Negative Differential Analog Input

When Pr **S.01.015** or Pr **S.01.016** are set to Digital Input (0), terminals T7 or T8 will be configured as digital inputs.

When Pr **S.01.015** or Pr **S.01.016** are set to Volt IN (1), terminals T7 or T8 will be configured as independent single ended analog voltage inputs.

When either Pr **S.01.015** or Pr **S.01.016** are set to Differential (2), the terminals T7 and T8 are combined so that they can be used as a high precision differential analog voltage input with T7 as the positive input and T8 as the negative input. This will disable the single ended analog voltage input parameters and they will not update.

A combination of setting these parameters to either Digital Input (0) or Volt IN (1) is permitted between the two terminals so that one terminal can be used as digital input and the other can be configured as a single ended analog voltage input.

Setting either of these parameters to Differential (2) will override any other value in the other mode parameter to configure both inputs as a single differential analog input.

NOTE

The value of Differential (2), is only available with SI-I/O firmware V01.00.01.xx and later. To use the differential analog input in previous firmware, Pr **S.01.015** and Pr **S.01.016** must both be set to Volt IN (1).

S.01.017	T9 Digital Input 7, Analog Input 3 Mode		
Minimum	0	Maximum	11
Default	1	Units	
Type	8 Bit User Save	Update Rate	Background read
Display Format	None	Decimal Places	0
Coding	RW, TE		

Terminal 9 can be configured as a digital input, an analog voltage input or an analog current input.

The table below shows all possible values of Pr **S.01.017**.

Value	Text	Description
0	Digital Input	Digital Input 7
1	Volt IN	±10 V Analog voltage Input
2	4-20 mA Low	4-20 mA switching to equivalent of 4 mA input current on loss
3	20-4 mA Low	20-4 mA switching to equivalent of 20 mA input current on loss
4	4-20 mA Hold	4-20 mA hold at level before loss on loss
5	20-4 mA Hold	20-4 mA hold at level before loss on loss
6	0-20 mA	0-20 mA
7	20-0 mA	20-0 mA
8	4-20 mA Trip	4-20 mA trip on loss
9	20-4 mA Trip	20-4 mA trip on loss
10	4-20 mA	4-20 mA no action on loss
11	20-4 mA	20-4 mA no action on loss

S.01.018	T9 Digital Input 8, Analog Output 1 Mode		
Minimum	0	Maximum	5
Default	1	Units	
Type	8 Bit User Save	Update Rate	Background read
Display Format	None	Decimal Places	0
Coding	RW, TE		

Terminal 11 can be configured as a digital input, an analog voltage output or an analog current output.

The table below shows all possible values of Pr **S.01.018**.

Value	Text	Description
0	Digital Input	Digital Input 7
1	Volt Out	±10 V Analog voltage Output
2	4-20 mA	4-20 mA output current
3	20-4 mA	20-4 mA output current
4	0-20 mA	0-20 mA output current
5	20-0 mA	20-0 mA output current

NOTE

The analog output is only supported on Unidrive M600 - M800.

7.3 Menu 2 - Digital I/O

Menu 2 on the module controls and displays all parameters associated with the Digital I/O.

S.02.001	Digital I/O 1 State		
S.02.002	Digital I/O 2 State		
S.02.003	Digital I/O 3 State		
S.02.004	Digital I/O 4 State		
S.02.005	Digital Input 5 State		
S.02.006	Digital Input 6 State		
S.02.007	Digital Input 7 State		
S.02.008	Digital Input 8 State		
S.02.009	Relay 1 State		
S.02.010	Relay 2 State		
Minimum	0	Maximum	1
Default	0	Units	
Type	1 Bit Volatile	Update Rate	2 ms read/write - Unidrive M600 - M800 8 ms read/write - Unidrive M200 - M400
Display Format	None	Decimal Places	0
Coding	RO, ND, ND, PT		

Digital I/O X State shows the state of the digital I/O in question. All I/O use IEC61131-2 logic levels. As default the inputs use positive logic, and so the state parameter is 0 if the digital I/O is low or 1 if the digital I/O is high. Digital I/O Logic Polarity (Pr **S.01.008**) can be set to Negative Logic (0) to change the logic for Digital I/O 1-8, so that the state parameter is 0 if the digital I/O is high and 1 if the digital I/O is low.

The state parameter represents the digital I/O state whether it is configured as an input or as an output. If the digital I/O is configured as an output to be controlled using the Digital I/O Register (Pr **S.01.007**), then the state parameter will still show the state of the output even though the source is zero.

For Relay 1 and 2, the state parameter is 0 if the relay contact is open, the state parameter is 1 if the relay contact is closed.

S.02.011	Digital I/O 1 Invert		
S.02.012	Digital I/O 2 Invert		
S.02.013	Digital I/O 3 Invert		
S.02.014	Digital I/O 4 Invert		
S.02.015	Digital Input 5 Invert		
S.02.016	Digital Input 6 Invert		
S.02.017	Digital Input 7 Invert		
S.02.018	Digital Input 8 Invert		
S.02.019	Relay 1 Invert		
S.02.020	Relay 2 Invert		
Minimum	0	Maximum	1
Default	0	Units	
Type	1 Bit User Save	Update Rate	Background read
Display Format	None	Decimal Places	0
Coding	RW		

A value of Off (0) or On (1) in Digital I/O X Invert allows the I/O state to be non-inverted or inverted as required.

S.02.021	Digital I/O 1 Source / Destination		
S.02.022	Digital I/O 2 Source / Destination		
S.02.023	Digital I/O 3 Source / Destination		
S.02.024	Digital I/O 4 Source / Destination		
S.02.025	Digital Input 5 Destination		
S.02.026	Digital Input 6 Destination		
S.02.027	Digital Input 7 Destination		
S.02.028	Digital Input 8 Destination		
S.02.029	Relay 1 Source		
S.02.030	Relay 2 Source		
Minimum	0.00.000	Maximum	4.99.999
Default	0.00.000	Units	
Type	32 Bit User Save	Update Rate	Drive Reset read
Display Format	Slot Menu Parameter	Decimal Places	0
Coding	RW, PT, BU		

The Digital I/O X Source / Destination parameters provide the routing for the source and/or destination for the digital I/O. Relay X Source provides the routing for the source of the two relays.

7.4 Menu 3 - Analog I/O

Menu 3 on the module controls and displays all parameters associated with the Analog I/O.

S.03.001	Analog Input 1		
S.03.002	Analog Input 2		
S.03.003	Analog Input 3		
Minimum	-100.00	Maximum	100.00
Default		Units	%
Type	16 Bit Volatile	Update Rate	250 μ s write
Display Format	None	Decimal Places	2
Coding	RO, FI, ND, NC, PT		

Analog inputs 1, 2 and 3 have a resolution of 12 bits. The input can operate in different modes as defined the mode selected in Pr **S.01.015** to Pr **S.01.017** including current modes.

The "Input Level" is defined for the different modes as shown in the table below.

Mode	Input Level
Volt IN	(Input Voltage / 10 V) x 100.00 %
0-20mA	(Input Current / 20 mA) x 100.00 %
20-0mA	((20 mA – Input Current) / 20 mA) x 100.00 %
4-20mA	((Input Current – 4 mA) / 16 mA) x 100.00 %
20-4mA	((20 mA – Input Current) / 16 mA) x 100.00 %

Analog Inputs 1-3 (Pr **S.03.001** to Pr **S.03.003**) are derived as follows (Analog Input 1 is used for this example):

A_1 is the value after the minimum and maximum limits are applied.

If Analog Input 1 Minimum (Pr **S.03.014**) \geq Analog Input 1 Maximum (Pr **S.03.015**) then: $A_1 = 0.00$ % whatever the input level is.

If Analog Input 1 Minimum (Pr **S.03.014**) $<$ 0.00% and Analog Input 1 Maximum (Pr **S.03.015**) $>$ 0.00 % then:

Input Level is limited between - Analog Input 1 Minimum (Pr **S.03.014**) and + Analog Input 1 Maximum (Pr **S.03.015**).

$A_1 = \text{Input Level} \times (100.00 \% / \text{Analog Input 1 Maximum (Pr S.03.015)})$

Otherwise:

Input Level is limited between Analog Input 1 Minimum (Pr **S.03.014**) and Analog Input 1 Maximum (Pr **S.03.015**).

$A_1 = [(\text{Input Level} - \text{Analog Input 1 Minimum (Pr S.03.014)}) \times 100.00 \%] / [\text{Analog Input 1 Maximum (Pr S.03.015)} - \text{Analog Input 1 Minimum (Pr S.03.014)}]$.

S.03.004	Differential Analog Input		
Minimum	-100.0000	Maximum	100.0000
Default		Units	%
Type	32 Bit Volatile	Update Rate	4 ms write
Display Format	None	Decimal Places	4
Coding	RO, ND, NC, PT		

The Differential Analog Input has a resolution of 16 bits. The minimum resolution of Pr **S.03.004** is 0.0030518 % (100 / 215 %).

The level of Differential Analog Input (Pr **S.03.004**) is calculated in the same way as Analog Inputs 1-3 (Pr **S.03.001** - Pr **S.03.003**).

NOTE

The differential analog input is only available on Unidrive M600 - M800.

S.03.005	Analog Output 1		
Minimum	-100.00	Maximum	100.00
Default	0.00	Units	%
Type	16 Bit Volatile	Update Rate	Background read
Display Format	None	Decimal Places	2
Coding	RO, PT		

Analog Output 1 (Pr **S.03.005**) has a resolution of 12 bits plus sign. Analog Output 1 (Pr **S.03.005**) shows the value passed by Analog Output 1 Source (Pr **S.03.006**) which is then scaled by Analog Output 1 Scaling (Pr **S.03.007**) and clamped between -100.00 and 100.00%.

NOTE

The analog output is only available on Unidrive M600 - M800.

S.03.006	Analog Output 1 Source		
Minimum	0.00.000	Maximum	4.99.999
Default	0.00.000	Units	
Type	32 Bit User Save	Update Rate	Background read
Display Format	Slot Menu Parameter	Decimal Places	
Coding	RW, BU		

Analog Output 1 Source (Pr **S.03.006**) defines the source parameter for T11 analog output 1.

NOTE

The analog output is only available on Unidrive M600 - M800.

S.03.007	Analog Output 1 Scaling		
Minimum	0.000	Maximum	40.000
Default	1.000	Units	
Type	16 Bit User Save	Update Rate	Background read
Display Format	None	Decimal Places	3
Coding	RW, BU		

Analog Output 1 Scaling (Pr **S.03.007**) defines the scaling that is applied to T11 analog output 1.

NOTE

The analog output is only available on Unidrive M600 - M800.

S.03.011	Analog Input 1 Offset		
S.03.021	Analog Input 2 Offset		
S.03.031	Analog Input 3 Offset		
S.03.041	Differential Analog Input Offset		
Minimum	-100.00	Maximum	100.00
Default	0.00	Units	%
Type	16 Bit User Save	Update Rate	Background read
Display Format	None	Decimal Places	2
Coding	RW		

S.03.012	Analog Input 1 Scaling		
S.03.022	Analog Input 2 Scaling		
S.03.032	Analog Input 3 Scaling		
S.03.042	Differential Analog Input Scaling		
Minimum	0.000	Maximum	40.000
Default	1.000	Units	
Type	16 Bit User Save	Update Rate	Background read
Display Format	None	Decimal Places	3
Coding	RW, BU		

S.03.013	Analog Input 1 Invert		
S.03.023	Analog Input 2 Invert		
S.03.033	Analog Input 3 Invert		
S.03.043	Differential Analog Input Invert		
Minimum	0	Maximum	1
Default	0	Units	
Type	1 Bit User Save	Update Rate	Background read
Display Format	None	Decimal Places	
Coding	RW		

All of the Analog Inputs will operate in the same way as shown below but only Analog Input 1 is used for reference.

Analog Input 1 (Pr **S.03.001**) is modified by Analog Input 1 Offset (Pr **S.03.011**), the Analog Input 1 Scaling (Pr **S.03.012**) and Analog Input 1 Invert (Pr **S.03.013**) before it is routed to its destination as follows:

$$A_{10} = \text{Analog Input 1 (Pr S.03.001)} + \text{Analog Input 1 Offset (Pr S.03.011)}$$

A_{10} is the value after the offset has been applied and is limited between -100.00 and 100.00 %

$$A_{1S} = A_{10} \times \text{Analog Input 1 Scaling (Pr S.03.012)}$$

A_{1S} is the value after the scaling and the offset have been applied and is limited between -100.00 and 100.00 %.

$$\text{If Analog Input 1 Invert (Pr S.03.013)} = 0 \text{ then } A_{1I} = A_{1S} \text{ otherwise } A_{1I} = -A_{1S}$$

A_{1I} is the value after the invert, scaling and offset have been applied and is the final value that is routed to the destination defined by Analog Input 1 Destination (Pr **S.03.016**).

S.03.014	Analog Input 1 Minimum		
S.03.024	Analog Input 2 Minimum		
S.03.034	Analog Input 3 Minimum		
S.03.044	Differential Analog Input Minimum		
Minimum	-100.00	Maximum	100.00
Default	-100.00	Units	%
Type	16 Bit User Save	Update Rate	Background read
Display Format	None	Decimal Places	2
Coding	RW		

S.03.015	Analog Input 1 Maximum		
S.03.025	Analog Input 2 Maximum		
S.03.035	Analog Input 3 Maximum		
S.03.045	Differential Analog Input Maximum		
Minimum	-100.00	Maximum	100.00
Default	100.00	Units	%
Type	16 Bit User Save	Update Rate	Background read
Display Format	None	Decimal Places	2
Coding	RW		

Pr **S.03.014** and Pr **S.03.015** control the minimum and maximum limits for Analog Input 1. See Analog Input 1 (Pr **S.03.001**) for more details.

S.03.016	Analog Input 1 Destination		
S.03.026	Analog Input 2 Destination		
S.03.036	Analog Input 3 Destination		
S.03.046	Differential Analog Input Destination		
Minimum	0.00.000	Maximum	4.99.999
Default	0.00.000	Units	
Type	32 Bit User Save	Update Rate	Drive reset read
Display Format	Slot Menu Parameter	Decimal Places	
Coding	RW, BU		

These parameters set the destination for each analog input in question. See Analog Input 1 (Pr **S.03.001**) for more details.

S.03.037	Analog Input 3 Current Loop Loss		
Minimum	0	Maximum	1
Default		Units	
Type	1 Bit Volatile	Update Rate	Background write
Display Format	None	Decimal Places	
Coding	RO, ND		

If T9 Digital Input 7 / Analog Input 3 Mode (Pr **S.01.017**) is set to any of the 4-20 mA or 20-4 mA modes and the current falls below 3mA, then Analog Input 3 Current Loop Loss (Pr **S.03.037**) will be set to On (1). If the current is greater than 3 mA or any other mode is selected, then Analog Input 3 Current Loop Loss (Pr **S.03.037**) will be set to Off (0).

7.5 Menu 9 - Resources

S.09.030	PCB Temperature		
S.09.031	CPU Core Temperature		
Minimum	-128	Maximum	127
Default	0	Units	°C
Type	8 Bit Volatile	Update Rate	Background write
Display Format		Decimal Places	
Coding	RO, NC, PT		

Pr **S.09.030** and **S.09.031** display the current temperature of the 2 internal thermistors inside the module.

8 Block diagrams

8.1 Functional block diagrams

Figure 8-1 Digital I/O 1/2

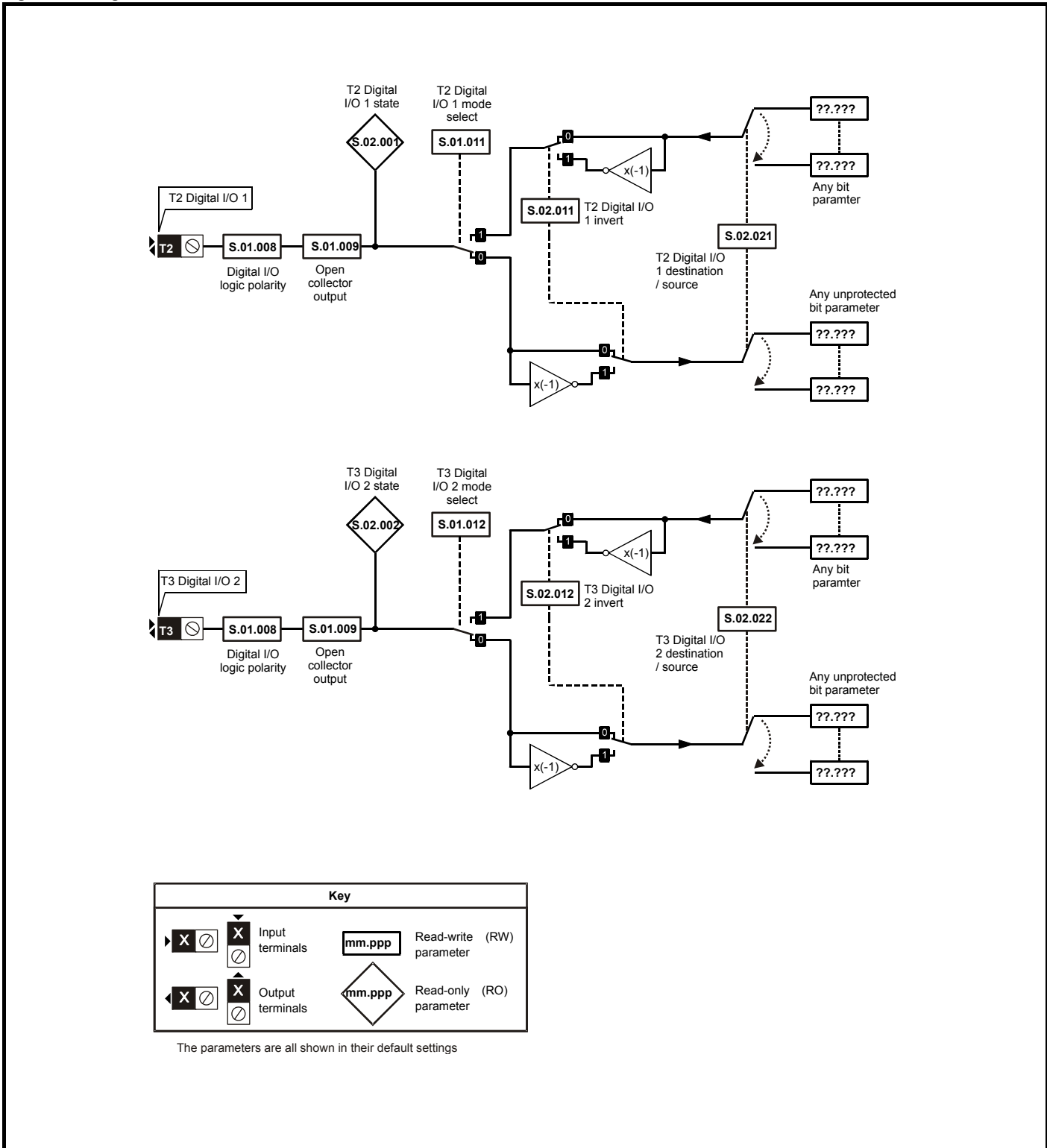

Figure 8-2 Digital I/O 3/4

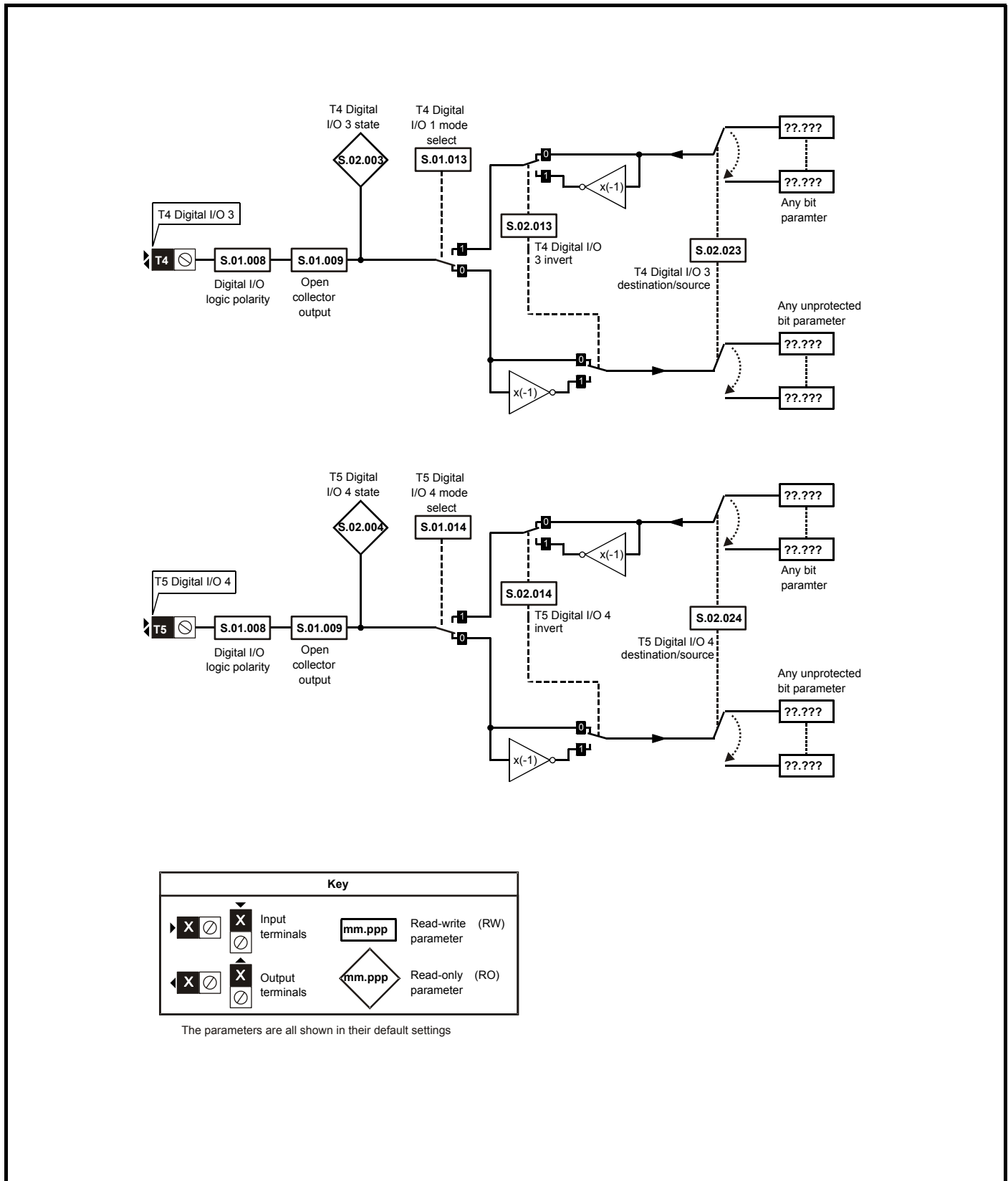

Figure 8-3 Digital input 5/6/7/8

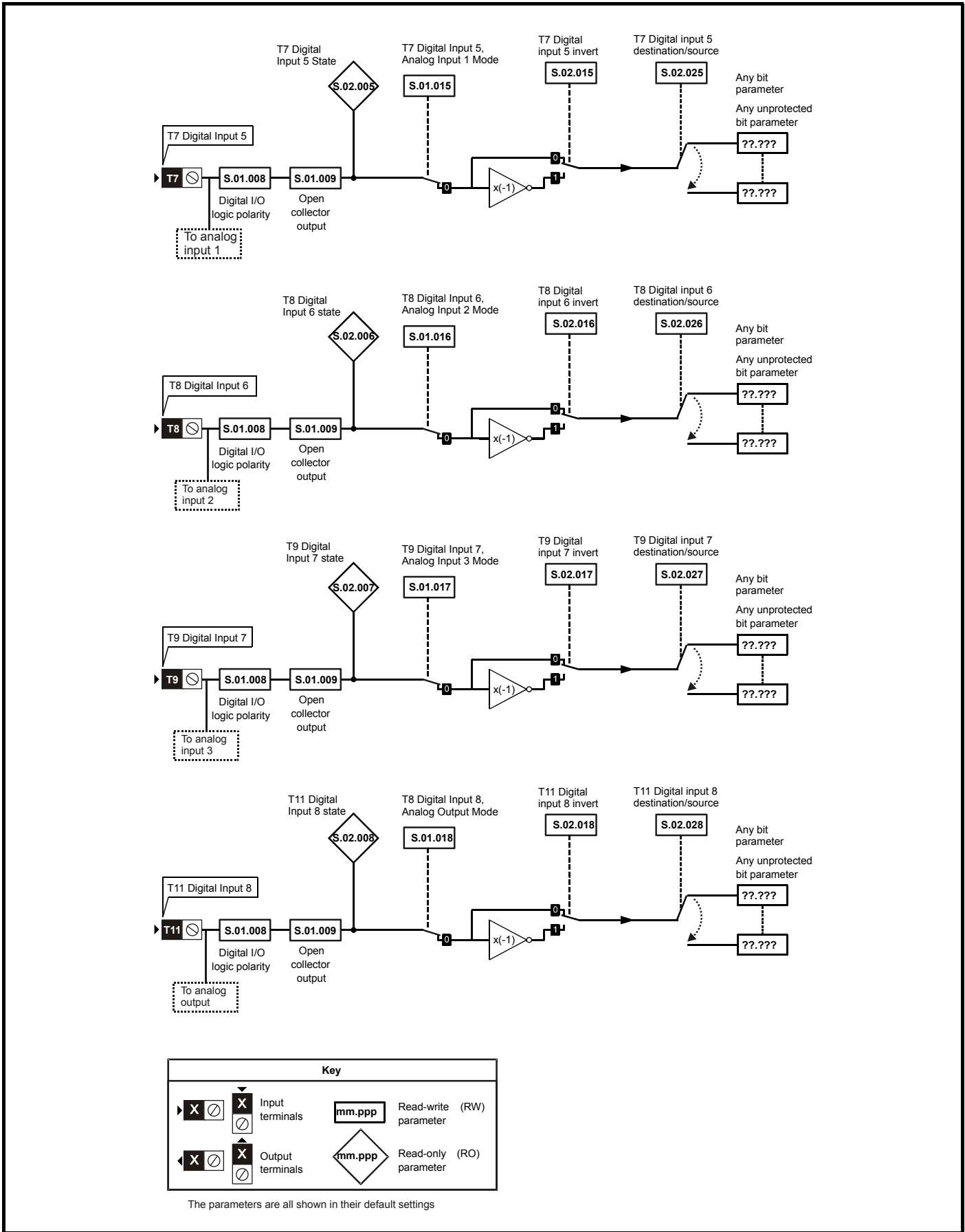

Figure 8-4 Analog input 1/2, differential analog input

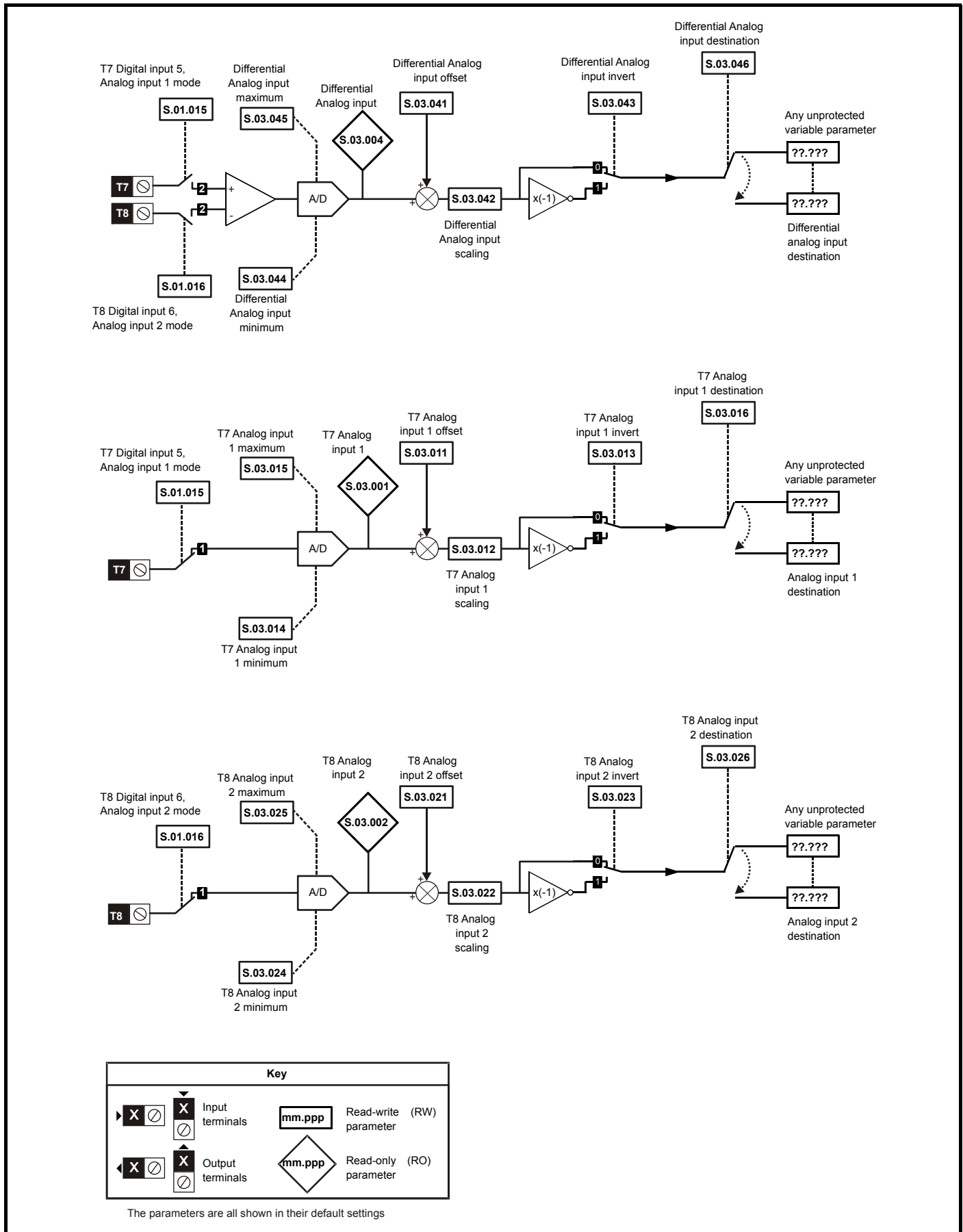

Figure 8-5 Analog input 3 and analog output 1

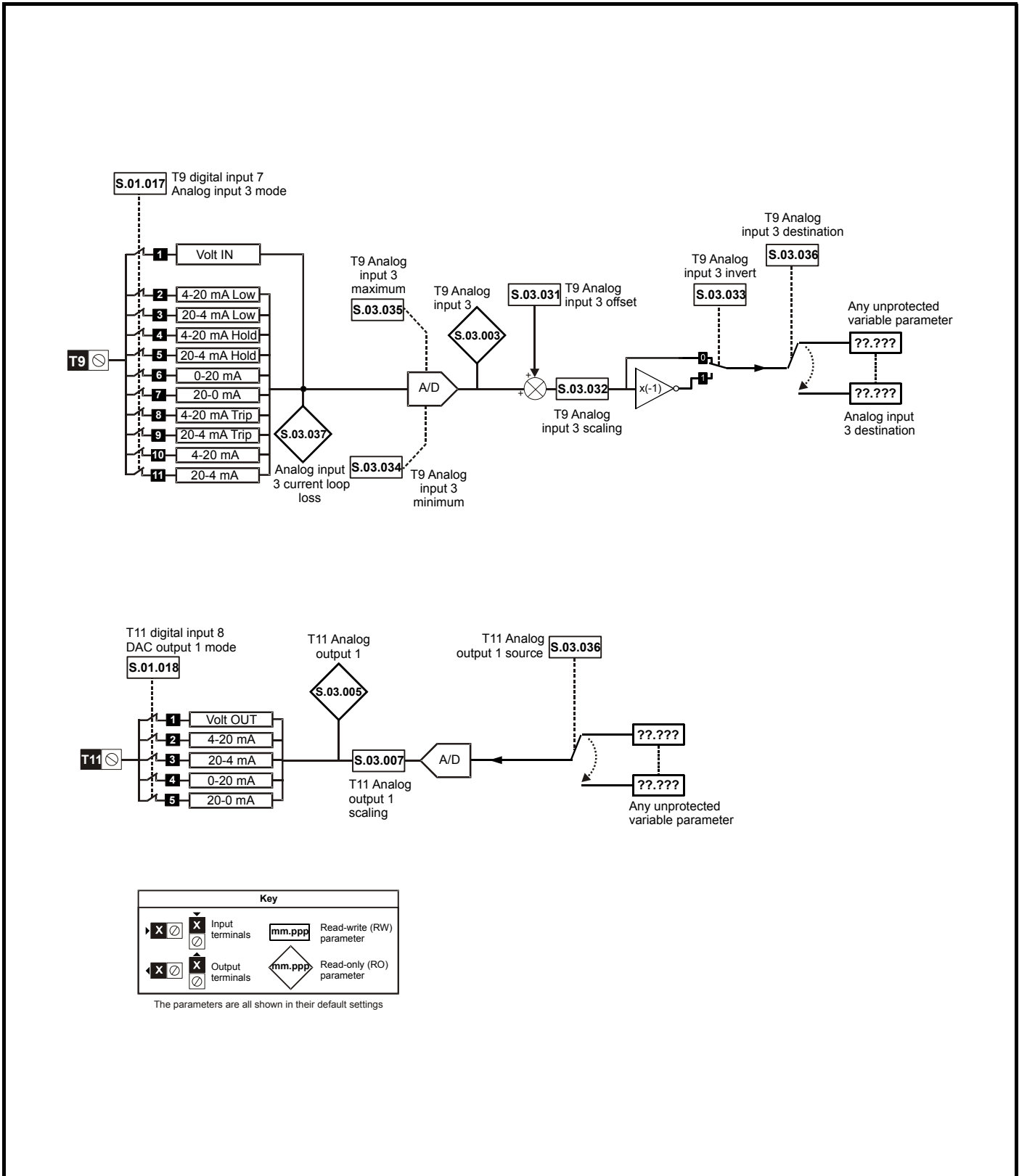
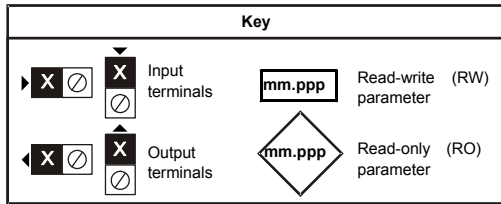
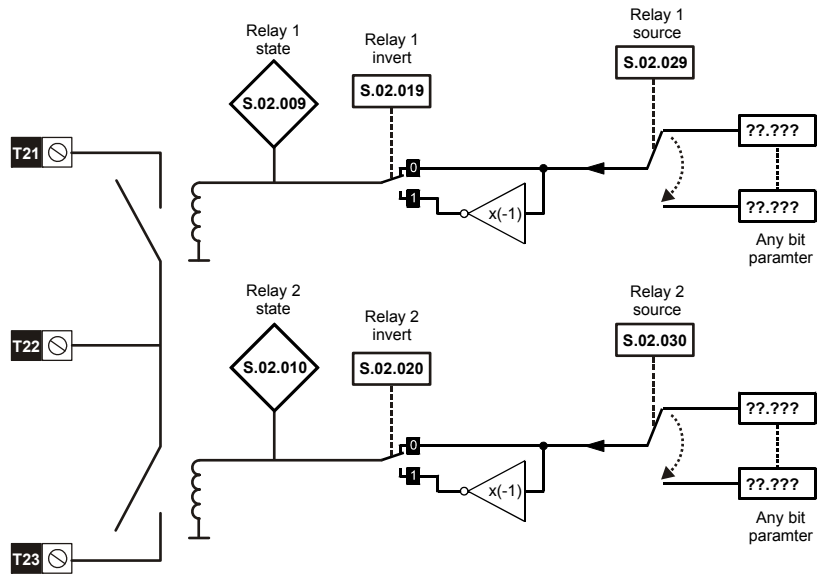

Figure 8-6 Relay output



The parameters are all shown in their default settings

9 Diagnostics

9.1 Overview

This section provides basic diagnostic information intended to resolve the most common problems encountered when setting up an SI-I/O option module.

Drive trip display codes

If the option module detects an error during operation, it will force a trip on the drive. However, the trip string displayed on the drive will only indicate which slot initiated the trip. The exact reason for the trip will be indicated in the drive trip code parameters (Pr **10.020** and Pr **10.070**).

Table 9.1 shows the possible trips that will be displayed on the drive when a problem is detected with the option module or when the option module initiates a trip.

Table 9.1 Digital I/O - 1-4

Trip	Description
SlotX HF	The drive has detected that an option module is present but is unable to communicate with it due to a hardware fault.
SlotX Error	User trip generated by the option module
SlotX Not Fitted	This trip will occur if a drive slot was previously configured with an option module but on power up, no option module was detected.
SlotX Different	This trip will occur if a drive slot was previously configured with an option module but on power up, a different option module was detected. Replacing the option module with another one of the same ID number will not initiate this trip. The trip will also occur if an option module is installed to a previously unused slot.

9.1.1 Module error codes

If the option module detects an internal error during operation, it will force a trip on the drive and provide a sub-trip string for a clearer definition of the trip. Table 9.2 shows the possible module error codes.

Table 9.2 Module error codes

Value	Text	Description
200	SW fault	Software fault
201	BG Orun	Background task overrun
202	FW invalid	Invalid firmware for hardware version
203	Drv unknown	Unknown drive type
204	Drv unsupported	Unsupported drive type
205	Mode unknown	Unknown mode
206	Mode unsupported	Unsupported mode
207	FLASH corrupt	Corrupted Non-volatile Flash
208	Dbase init	Database initialization error
209	FS init	File system initialization error
210	Memory alloc	Memory allocation error
211	Filesystem	File system error
212	Configuration	Configuration file error
213	Oht	Overheated
214	TO drv	The drive has not responded with the watchdog period
215	eCMP	eCMP comms failure
216	TO eCMP slot 1	Slot 1 eCMP timeout
217	TO eCMP slot 2	Slot 2 eCMP timeout
218	TO eCMP slot 3	Slot 3 eCMP timeout
219	TO eCMP slot 4	Slot 4 eCMP timeout
220	Output overload	Digital output overload

9.1.2 I/O error codes

If the Option module detects an I/O error during operation, it will force a trip on the drive and provide a sub-trip string for a clearer definition of the trip. Table 9.3 shows all possible I/O error codes.

Table 9.3 I/O error codes

Value	Text	Description
100	DIO Overload	Digital Input/Output overload
101	Cur LoopLoss	Analog Input 3 has entered the Current Loop Loss condition
102	T9 OverVolt	The over voltage condition has been detected on terminal 9
103	Param Occupied	There is a destination conflict between two destination parameters on the module

10 Technical Data

10.1 Digital inputs/outputs (Terminals 2-5)

Default function	Positive logic mode
Type	Positive or negative logic inputs or Negative logic push-pull or open collector outputs
Absolute maximum voltage range	-18 V to +36 V
Update time	2 ms for Unidrive M600 - M800 8 ms for Unidrive M200 - M400
Operating as an input	
Logic mode controlled by	Pr S.01.008
Voltage range	0 V to +24 V
Impedance	>2 mA @ +15 Vdc from IEC61131-2, clause 3.3.1 type 1
Input thresholds	10 V \pm 0.8 V
Operating as an output	
Mode controlled by	Pr S.01.009
Current limits	100 mA for Digital I/O 1&2 100 mA for Digital I/O 3&4
Isolation	Not isolated from control circuit
Overvoltage protection	Series resistor, filter capacitor and clamping diodes

10.2 Digital Inputs (Terminals 7-9)

Default function	Positive logic mode
Type	Positive or negative logic inputs
Absolute maximum voltage range	-18 V to +36 V
Update time	2 ms for Unidrive M600 - M800 8 ms for Unidrive M200 - M400
Operating as an input	
Logic mode controlled by	Pr S.01.008
Voltage range	0 V to +24 V
Impedance	>2 mA @ +15 V dc from IEC61131-2, clause 3.3.1 type 1
Input thresholds	10 V \pm 0.8 V

10.3 Differential Analog Input (Terminals 7 and 8)

(Unidrive M600 - M800 only)

Type	Bipolar differential analog input
Full scale voltage range	\pm 10 V \pm 1 %
Absolute maximum voltage range	-18 V to +36 V
Differential Input resistance	>100k Ω
Resolution	16 bit
Maximum offset	50 mV
Maximum nonlinearity	0.3 % of input
Input filter bandwidth single pole	\approx 1 kHz
Sample period	2 ms
Over voltage protection	Not isolated from control circuit

10.4 Single-ended Analog Inputs (Terminals 7-9) in Voltage input mode

Type	Bipolar single-ended analog voltage input
Full scale voltage range	$\pm 10 \text{ V} \pm 1 \%$
Absolute maximum voltage range	-18 V to +36 V
Input resistance	>20k Ω
Resolution	12 bit
Maximum offset	50 mV
Maximum nonlinearity	0.3 % of input
Sample period	2 ms for Unidrive M600 - M800 8 ms for Unidrive M200 - M400
Over voltage protection	Over voltage protected by clamping diodes
Input filter bandwidth	$\approx 1 \text{ kHz}$

10.5 Single-ended Analog Input (Terminal 9) in Current input mode

Type	Bipolar single-ended analog current input
Full scale current range	0-20 mA $\pm 1 \%$
Absolute maximum voltage range	-18 V to +36 V
Input resistance	120 Ω
Resolution	$\pm 1 \%$
Maximum input current	30 mA
Maximum nonlinearity	0.3 % of input
Sample period	2 ms for Unidrive M600 - M800 8 ms for Unidrive M200 - M400
Over current protection	Over current protection @ 27.5 mA

10.6 Analog Output (Terminal 11) in Voltage output mode

(Unidrive M600 - M800 only)

Type	Bipolar single-ended analog voltage output
Full scale output voltage range	$\pm 10 \text{ V} \pm 1 \%$
Absolute maximum voltage range	-18 V to +36 V
Output resistance	<200 Ω
Resolution	12 bit+
Maximum current	$\pm 30 \text{ mA}$ short-circuit protected
Minimum load resistance	1k Ω
Maximum load capacitance	150 nF
Gain accuracy	2 % typical
Offset	$\pm 50 \text{ mV}$
Maximum gain asymmetry	0.1 %
Setting time to within 100mV after a 10V change	300 μs
Setting time to within 10mV after a 10V change	3 ms
Update time	2 ms
Isolation	Not isolated from control circuit

10.7 Analog Output (Terminal 11) in Current output mode

(Unidrive M600 - M800 only)

Type	Monopole single-ended analog current output
Full scale output voltage range	0-20 mA \pm 1 %
Absolute maximum voltage range	\pm 36 V
Output resistance	<200 Ω
Minimum load resistance	200 Ω
Maximum load resistance	600 Ω
Resolution	12 bit
Maximum current	\pm 30 mA short-circuit protected
Offset	\pm 1 mA
Maximum gain asymmetry	0.1 %
Update time	2 ms
Isolation	Not isolated from control circuit

10.8 Relays (Terminals 21-23)

Voltage rating	240 Vac, Installation category II
Contact maximum current rating	2 A AC 240 V 5 A DC 30 V resistive load 0.5 A DC 30 V inducting load (L/R = 40 ms)
Contact form	Closed when power applied
Update time	2 ms for Unidrive M600 - M800 8 ms for Unidrive M200 - M400



Category 1 installations must have suppression to limit supply-borne transients to a maximum of 1,500 V peak.

Index

Numerics

24V internal power supply8

A

Access5

Adjusting parameters5

Analog I/O8

C

Compliance with regulations5

Conventions used in this guide7

D

Date code7

Diagnostics34

Digital I/O8

Drive software2

E

Electrical safety5

Environmental limits5

F

Features7

Functional block diagrams28

G

General installation9

I

I/O error codes35

Installing the first Option module9

Intended personnel4

M

Menu 0 - Setup11

Menu 1 - I/O Set-up18

Menu 2 - Digital I/O23

Menu 3 - Analog I/O24

Menu 9 - Resources27

Module error codes34

N

Notes5

O

Option module identification7

P

Parameters - adjusting5

R

Relays8

S

Safety Information4, 5

Safety information5

Single line descriptions11

Stored charge6

System design and safety of personnel5

T

Technical Data36

Terminal descriptions10

W

Warnings, Cautions and Notes5

Wiring, shield connections10



SCIGATE AUTOMATION (S) PTE LTD

No.1 Bukit Batok Street 22 #01-01 Singapore 659592

Tel: (65) 6561 0488

Fax: (65) 6562 0588

Email: sales@scigate.com.sg

Web: www.scigate.com.sg

Business Hours: Monday - Friday 8.30am - 6.15pm



0478-0047-03